

2021 EXPO Cheat Sheet

Atlantic Builders Convention Conference & Expo

For additional information & updates, please visit: www.abconvention.com

1. HEALTH & SAFETY

Proof of full vaccination or a negative COVID test will be required to gain entry to the 2021 Atlantic Builders Convention. Show Management is working through the logistics of administering this policy and further details will be forthcoming. All attendees are also strongly encouraged to follow all CDC mask recommendations.

2. RULES & REGULATIONS

All rules and regulation including union jurisdiction rules, Harrah's waterfront conference center regulations, and the terms & conditions are posted on www.abconvention.com. For your protection, please review them.

3. ORDER FORMS

All order forms are accessible via the ABC website at <https://www.abconvention.com/exhibit/>. The AEX Convention Services **deadline for discount prices is September 27, 2021**. All Orders Received after that date will be charged at a higher rate.

4. SHIPPING AND DRAYAGE:

We are, once again, proud to offer through our special arrangement with AEX Convention Services a waiver of Inbound/Outbound overtime charges for your freight shipped to the advance warehouse as well as show site. This means that if your freight arrives during the dates specified in the Exhibitor Kit overtime charges will not be incurred by you for freight loaded or unloaded during overtime periods.

Shipping to the AEX Convention Services Warehouse - The official drayage contractor for our show is AEX Convention Services. Phone: (609) 272-1600. Exhibits may be shipped to their warehouse prior to the show for delivery to the Conference Center. Shipping to the AEX Convention Services warehouse will ensure that your materials will be in your booth by 8AM on Monday, October 11, 2021. If you have any questions or would like assistance, please call AEX Convention Services at (609) 272-1600. The shipping address for the AEX Warehouse is provided in the AEX Exhibitor Kit which is available via the ABC website at <https://www.abconvention.com/exhibitor-forms/exhibitor-kit/>. It is important that your shipment has a bill of lading showing the number of pieces, weight and description of merchandise, your company name and booth number. Shipments without a bill of lading or documented weight will be estimated and the estimated weight will be binding on both parties. Advanced shipping must arrive at the AEX Convention Services warehouse **no later than Wednesday, October 4, 2021.**

Delivery to the Harrah's Waterfront Conference Center - On Monday, October 11 from 8 AM until 5 PM exhibitors may deliver their materials to the property. Upon arrival, all drivers should register with AEX Convention Service supervisory personnel. Unloading of all trucks will be done on a first come, first serve basis. Self-unloading will also be available during this time. All exhibitors delivering materials to the Harrah's Waterfront Conference Center in their own vehicles must remember that no vehicles will be allowed to be left unattended once the exhibit is unloaded. To avoid delays unloading your exhibit, it is recommended that exhibitors ship through the drayage company. Exhibitors delivering materials to the dock in a privately-owned vehicle (POV) may use their own hand carts, luggage carts or dollies. A POV is a privately-owned vehicle (no rental or company vehicles) no larger than a minivan or SUV. There will be no self-unloading available on Tuesday, October 12. The Harrah's Waterfront Conference Center will not accept shipments.

5. LABOR POLICY

AEX Convention Services' exhibitor friendly labor policy can bring great benefits and savings to exhibitors. There will be no restrictions on exhibitors working in their inline booths up to and including 10' x 30' and island booths up to and including 20' x 20' if all persons in the booth are fulltime employees of the exhibitor. For inline booths that are larger than 10' x 30' and islands larger than 20' x 20' labor will be provided by the Carpenters Union and billed on a per hour basis. Take advantage of the discount price by ordering your labor prior to the **deadline of September 27,**

2021. If you have any questions, please contact the AEX Convention Services Office at (609) 272-1600.

In addition, AEX Convention Services will offer labor to those exhibitors who wish to hire AEX Convention Services employees to work in the booth.

To order labor service, access the order form via the ABC website at <https://www.abconvention.com/exhibitor-forms/exhibitor-kit/>.

6. INSTALLATION OF EXHIBITS

Monday, October 11, 2021

8AM – 5PM all exhibits

Tuesday, October 12, 2021

7AM – 9AM (limited set-up only)

All exhibits should be set up by 5 pm on October 11, 2021. Minor finishing work between 7 AM and 9 AM on October 12 will be permitted.

7. DISMANTLING OF EXHIBITS

- Exhibitors are required to keep their space manned until 4:00 pm on Wednesday, October 13, 2021. No move-out or dismantling may begin before this time. Refer to your signed Contract and the Rules & Regulations provided on www.abconvention.com. **All violators will be assessed a fine and lose their priority status for the 2022 Convention.**
- Exhibitors must provide personnel who pick up their exhibit with proper identification and a listing of the merchandise to be removed from the Harrah's Waterfront Conference Center. Guards will be on duty at the freight entrance to ensure that this procedure is complied with.
- Information regarding outbound shipments may be obtained from the AEX Convention Services service desk located in the main registration area. If for any reason you wish to have your exhibit returned to the AEX Convention Services warehouse and held for pick up later, these arrangements can also be handled at the AEX service desk before the close of the show.
- **All exhibits must be removed from the exhibit area by 10:00 PM on Wednesday, October 13, 2021.** The Harrah's Waterfront Conference Center will **NOT** allow storage of exhibits after this time. Any exhibitor who has not packed their booth ready for removal by 10:00 PM will have their booth dismantled, packed and removed by the official service contractors. The exhibitor will be responsible for charges involved.

8. EXHIBIT HOURS

- The exhibit show floor will be open for the following hours:
Tuesday, October 12, 2021 10AM – 4PM
Wednesday, October 13, 2021 10AM – 4PM
- Exhibitors will be allowed into the exhibit area one hour prior to the start of the show.

9. BOOTH RESTRICTIONS – Restrictions will be strictly enforced on-site.

- Each booth (except for booths located on the Main Aisle) is draped 8' high on the backline and 42" high on the sideline.
- All Main Aisle center spaces must adhere to an open-concept booth design. A design plan must be submitted to Show Management for approval – no exceptions.
- The sidelines of adjoining booths cannot exceed 42" for the 5' closest to the aisle so as not to obstruct sight lines of neighboring exhibitors. The maximum height of 8' is allowed only in the rear half of the booth space.

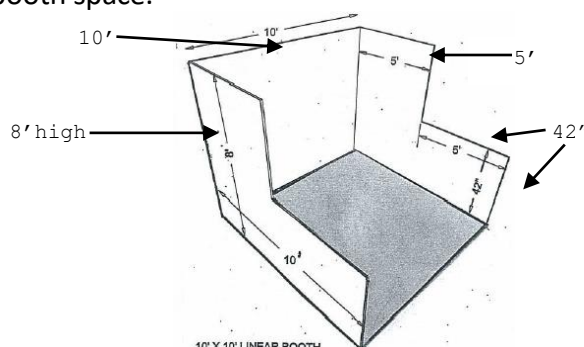

- Any display extending above the 42" side-rail must ensure that all exposed areas facing the adjoining neighboring booth are finished off with board, drape or some other comparable

material. These areas facing your adjoining neighbor should not have any company name, logo or any other advertising copy.

- Any exhibitor occupying a 10' x 20' or larger exhibit space on the main aisle must adhere to an "open concept" design. All exhibitors must submit a design plan upon space reservation to be approved by Show Management.
- Helium Balloons - Helium balloons are permitted in the Center only when they are securely anchored to exhibits. Balloons may not be given away. A fee will be charged by the Harrah's Waterfront Conference Center for the removal of any balloons that rise to the ceiling.
- Propane tanks are NOT allowed into the conference center.
- Fuel Operated Vehicles - Fuel tank must be only 1/8 full and have a locking gas cap.
- The battery must be disconnected at both leads. Contact AEX Convention Services to coordinate arrival time.
- It is expressly understood that no "wet" masonry or plastering fabrication will be permitted. Exhibitors will be responsible for any damage, which might result, to buildings or furnishings because of their exhibit.
- Noisy exhibits, or those in bad taste in the judgment of the ABC, will not be permitted. ABC reserves the right to remove any objectionable exhibits, persons, advertisements, or any other feature or action, which might not conform to the high standards of the convention. In such instances, there will be no refunds.
- All aisle space is subject to local fire regulations and shall not be used for demonstration purposes or oversized displays.
- No attachments are to be made to the building.

10. LIABILITY

- The New Jersey Builders Association (NJBA), the Atlantic Builders Convention (ABC), Harrah's Resort Atlantic City, Caesars Entertainment and AEX Convention Services are not responsible for any injury to any exhibitor or the exhibitor's employee or property, or for the loss by theft, fire, damage, delay or any cause whatsoever, while exhibits and merchandise are in transit to or from the building, or while in the building.
- All materials that are to be used at this convention shall comply with the provisions of federal, state, or local codes or regulations of any agency having jurisdiction.
- We urge you to review this information and if you have any questions, do not hesitate to contact the ABC office (609) 587-5577. Additionally, it is imperative that you share this information with members of your staff who are responsible for your booth.

11. SPONSORSHIPS

ABC offers a wide array of advertising and marketing opportunities to help enhance your presence on the exhibit floor. We encourage you to visit the ABC website at www.abconvention.com/sponsorship-opportunities/ for details.

12. BOOTH - CATERING

All food and beverage items must be supplied and prepared by the Harrah's Resort Atlantic City. Food items may not be removed from the premises or to be transferred to guest rooms or hospitality suites as per the Health Department Regulations. No food or beverage may be brought into the Harrah's Resort Atlantic City by a guest or attendee including exhibitors.