

# EXPO GUIDELINES

For Atlantic Builders Convention

For additional detailed information, order forms & updates

Please visit: [www.abconvention.com](http://www.abconvention.com)

**Exhibitor's Copy**  
Important Reference Info.  
Keep For Your Files

## 1. UNION JURISDICTION RULES, ACCC REGULATIONS, TERMS & CONDITIONS

are posted on the ABC website ([www.abconvention.com](http://www.abconvention.com)), **for your protection, please review them.**

- **ALL ORDER FORMS** will be available ON-LINE for your convenience ([www.abconvention.com](http://www.abconvention.com)).
- The AEX Convention Services DEADLINE FOR DISCOUNT PRICES IS **March 30, 2011.**  
**Warning** – All Orders Received After That Date Will Be Charged at a Much Higher Rate.

## 2. SHIPPING AND DRAYAGE:

We are once again proud to offer through our special arrangement with AEX Convention Services a waiver of Inbound/Outbound overtime charges for your freight shipped to the advance warehouse as well as show site. This means that as long as your freight arrives during the dates specified in the Exhibitor Kit overtime charges will not be incurred by you for freight loaded or unloaded during overtime periods.

- **Shipping to the AEX Convention Services Warehouse** - The official drayage contractor for our show is AEX Convention Services. Phone: (609) 272-1600 Fax: (609) 272-1680. Exhibits may be shipped to their warehouse prior to the show for delivery to the Convention Center. Shipping to the AEX Convention Services warehouse will insure that your materials will be in your booth by 8:00 am on Tuesday, April 5, 2011. If you have any questions or would like assistance, please call AEX Convention Services at (609) 272-1600.
- It is important that your shipment has a bill of lading showing the number of pieces, weight and description of merchandise, your company name and booth number. Shipments without a bill of lading or documented weight will be estimated and the estimated weight will be binding on both parties.
- Advanced shipping **must arrive** at the AEX Convention Services warehouse **no later than Wednesday, March 30, 2011.**
- **Shipping Direct to the Atlantic City Convention Center** - On Monday, April 4 from 1:00 pm until 5:00 pm and again on Tuesday April 5 from 8:00 am until 5:00 pm exhibitors may deliver their materials to the Convention Center. Upon arrival, all drivers should register with AEX Convention Service supervisory personnel. Unloading of all trucks will be done on a first come, first serve basis. On Mon., April 4 any and all deliveries will be unloaded by AEX Convention Services and subject to drayage charges. Self unloading will only be available on Tuesday April 5.
- All exhibitors delivering materials to the Convention Center in their own trucks must remember that no vehicles will be allowed to be left unattended once the exhibit is unloaded. In order to avoid delays unloading your exhibit, it is recommended that exhibitors ship through the drayage company.
- Exhibitors delivering materials to the dock in a privately owned vehicle (POV) may hand carry materials into the exhibit area provided no hand trucks or dollies are used. There will be no self unloading available on Mon., April 4.
- The Atlantic City Convention Center will not accept shipments prior to the start of the convention.

## 3. LABOR POLICY

AEX Convention Services' exclusive labor policy will bring great benefits and savings to all exhibitors. There will be no restrictions on exhibitors working in their booth as long as all persons in the booth are fulltime employees of the exhibitor.

In addition AEX Convention Services will offer labor to those exhibitors who wish to hire AEX Convention Services employees to work in the booth. Labor is provided by the Stagehand Union. AEX Convention Services is proud to be the only company, which can offer this wonderful and cost effective savings.

To order labor service, please visit the Atlantic Builders Convention website at [www.abconvention.com](http://www.abconvention.com) and download the order form. If you have any questions, please contact the AEX Convention Services Office at (609) 272-1600.

## 4. INSTALLATION OF EXHIBITS

- Exhibits 20' x 20' or larger ONLY:  
Monday, April 4, 2011: 1:00 pm - 5:00 pm
- All Exhibits:  
Tuesday, April 5, 2011: 8:00 am - 5:00 pm

All exhibits **MUST** be fully set up by 5:00 pm on Tuesday, April 5, 2011  
Absolutely **NO** set-ups will be allowed on Wednesday, April 6, 2011

## 5. DISMANTLING OF EXHIBITS

- Exhibitors are required to keep their space manned until 2:00 pm on Friday, April 8, 2011.
- **NO** move-out or dismantling may begin before this time. Refer to your signed Contract and the Jurisdictions and Rules & Regulations provided "On-Line". **All violators will be assessed a fine and lose their priority status for the 2012 Convention.**
- Exhibitors must provide personnel who pick up their exhibit with proper identification listing the merchandise to be removed from the Convention Center. Guards will be on duty at the freight entrance to ensure that this procedure is complied with.
- Information regarding outbound shipments may be obtained from the AEX Convention Services service desk located in the main registration area. If for any reason you wish to have your exhibit returned to the AEX Convention Services warehouse and held for pick up at a later date, these arrangements can also be handled at the AEX service desk before the close of the show.
- All exhibits must be removed from the exhibit area by **12:00 Midnight on Friday, April 8.** The Convention Center will **NOT** allow storage of exhibits after this time. Any exhibitor who has not packed his booth ready for removal by 12:00 Midnight will have his booth dismantled, packed and removed by the official service contractors. The exhibitor will be responsible for charges involved.

## 6. EXHIBIT HOURS

- The exhibit show floor will be open for the following hours (**NEW** hours Wed. - Fri.):  
WEDNESDAY, April 6 \*11:00 am - 5:00 pm  
THURSDAY, April 7 \*11:00 am - 5:00 pm  
FRIDAY, April 8 \*10:00 am - 2:00 pm
- NEW** - Exhibitors will be allowed into the exhibit area **two hours** prior to the start of the show **only** on Wed., April 6. On Thurs., April 7 and Fri., April 8 - exhibitors will only be allowed onto the floor **one hour** prior.
- Food service will be available in the exhibit area each day.  
*\*Note: Hours are subject to change without prior notice.*

## 7. BOOTH RESTRICTIONS

- Each booth is draped 8' high on the backline and 42" high on the sideline.
- The sidelines of adjoining booths cannot exceed 42" for the 5' closest to the aisle so as not to obstruct sight lines of neighboring exhibitors. The maximum height of 8' is allowed only in the rear half of the booth space.

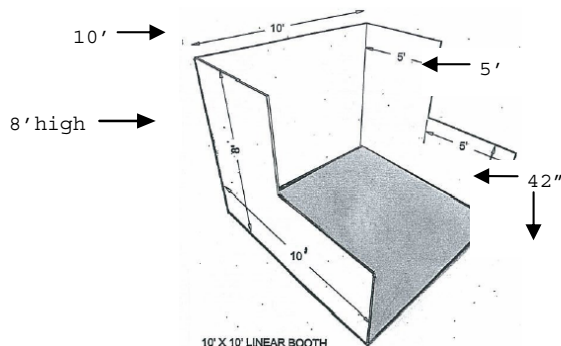

- Any display extending above the 42" side-rail must ensure that all exposed areas facing the adjoining neighboring booth are finished off with board, drape or some other comparable material. These areas facing your adjoining neighbor should not have any company name, logo or any other advertising copy.
- Helium Balloons - Helium balloons are permitted in the Center only when they are securely anchored to exhibits. Balloons may not be given away. A fee will be charged by the Convention Center for the removal of any balloons that rise to the ceiling.
- Propane tanks are NOT allowed into the convention center.
- Fuel Operated Vehicles - Fuel tank must be only 1/4 full and have a locking gas cap. The battery must be disconnected at both leads. Contact AEX Convention Services to coordinate arrival time.
- It is expressly understood that no "wet" masonry or plastering fabrication will be permitted. Exhibitors will be responsible for any damage, which might result, to buildings or furnishings as a result of their exhibit.
- Noisy exhibits, or those in bad taste in the judgment of the ABC, will not be permitted. ABC reserves the right to remove any objectionable exhibits, persons, advertisements, or any other feature or action, which might not conform to the high standards of the convention. In such instances, there will be no refunds.
- All aisle space is subject to local fire regulations and shall not be used for demonstration purposes or oversized displays.
- No attachments are to be made to the building.

## 8. LIABILITY

- The Atlantic Builders Convention (ABC), the Atlantic City Convention Center and AEX Convention Services are not responsible for any injury to any exhibitor or the exhibitor's employee or property, or for the loss by theft, fire, damage, delay or any cause whatsoever, while exhibits and merchandise are in transit to or from the building, or while in the building.
- All materials that are to be used at this convention shall comply with the provisions of federal, state, or local codes or regulations of any agency having jurisdiction.
- We urge you to review this information and if you have any questions, do not hesitate to contact the ABC office (609) 587-5577. **Additionally, it is imperative that you share this information with members of your staff who are responsible for your booth.**

## 9. EXHIBIT AWARDS

A committee of judges will view the exhibits and awards will be presented for the following categories:

- ◆ 1<sup>st</sup>, 2<sup>nd</sup> & 3<sup>rd</sup> Place - BEST DISPLAY (20' x 20' or larger)
- ◆ 1<sup>st</sup>, 2<sup>nd</sup> & 3<sup>rd</sup> Place - BEST DISPLAY (10' x 10')
- ◆ BEST MINI BOOTH DISPLAY

## 10. PROMOTIONAL MATERIALS

ABC will provide an on-line package of promotional materials your company may use to promote your booth/participation at the show (i.e., virtual postcard, widget for your website, etc.). We encourage you to use these items to create maximum exposure for your participation. Once this packet becomes available, ABC will send more information via e-mail. Visit the ABC website this summer at [www.abconvention.com](http://www.abconvention.com) for details.

## 11. BOOTH - CATERING

Any exhibitor offering food and/or beverage sampling must first be approved in advance.

Upon approval, we ask the exhibitor adhere to the following:

- Arrangements for food and beverage items, used as traffic promoters (i.e. popcorn, ice cream, coffee, candy, alcohol), must be arranged through the catering dept.
- Other items dispensed are limited to products manufactured, processed or distributed by the exhibiting firm and must be directly related to participation in the event.
- Food items must be limited to "sampling" or "bite-size" portions. Liquids or beverages are limited to 4 ounces; food products are limited to 2 ounces.
- Booth attendants, Bartenders, Kitchen runners and Ice Services may be contracted through the Food & Beverage department.
- Some dry and refrigerated storage may be available, but must be requested through the Food & Beverage Department. A fee may accompany this service.
- All services and payments must be contracted with Ovations separately. If you are planning to use the catering services, please call our ABC Ovations contact directly at 609-449-2058, or send e-mail to: [Jennifer.ice@ovationsfs.com](mailto:Jennifer.ice@ovationsfs.com). You can also download the order form at: [www.abconvention.com](http://www.abconvention.com).